



COMPANY PROFILE

AVENIR thanks to a GREAT EQUIPE with experience gained by over 20 years in multinationals of the sector, PRODUCES and sells since 2006 Dental IMPLANTOLOGY systems and since 1996 Endodontic Posts systems in Fiberglass / Carbon.

Our company organization, composed by Managers, Product Specialists, Biomedical/ Aeronautic/Mechanic Engineers, Product Designers, graduates in Chemistry and Pharmacy, as well as HIGHLY QUALIFIED Staff of CNC Works and Packaging, is certified ISO 9001 and ISO 13485 for the design and production of Medical Devices.

We make QUALITY and INNOVATION our corporate VALUE, that we pursue through constant investments in human resources and in latest generation technologies, as in CNC production machines as in advanced control instruments. Over the years this has made us reliable PARTNERS of prestigious brands in the Dental and Medical sectors, working with flexibility and timeliness in support of the ideas and projects that our Customer wants to develop and industrialize, according to their own specifications, having also the authorization to place on the market the Medical Devices with marking  issued by the Notified Body  updated to the new Regulation MDR 2017/745.





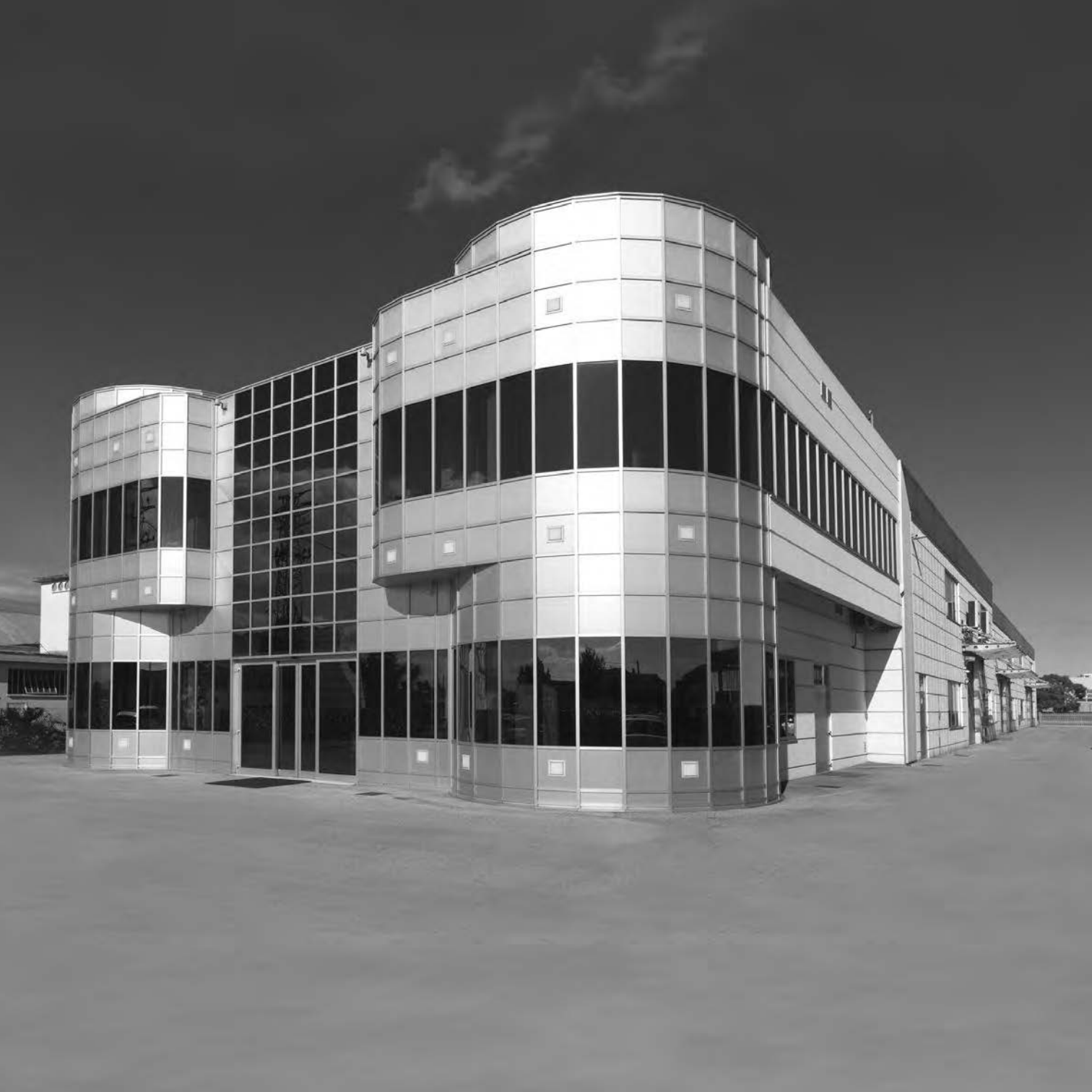

OUR STRUCTURE

Headquarters in Santarcangelo di Romagna (Italy)
4.000 square meters, 3.000 of which dedicated to production



MISSION

Create value for our customers.

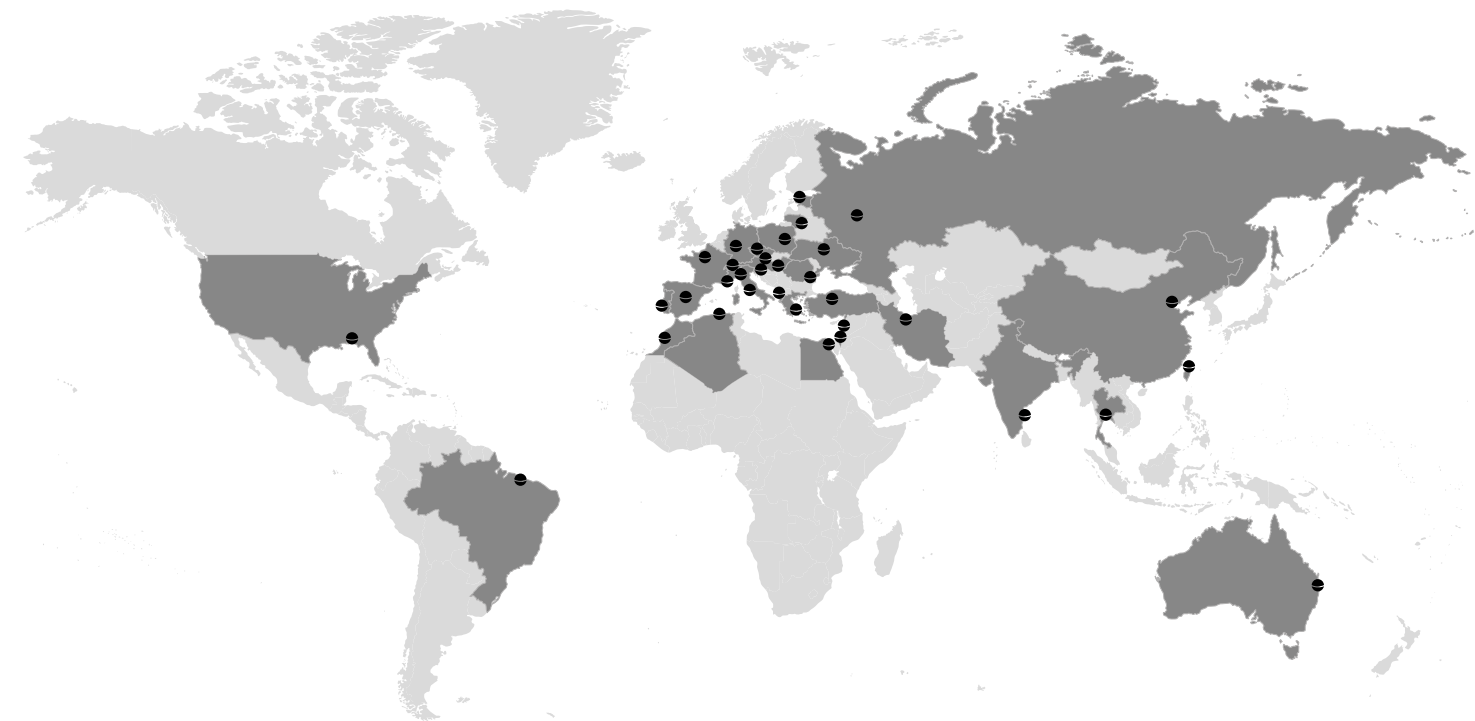

● Customers in 34 countries of the world

WE'RE FOR YOU

Major companies, Implant manufacturers, Multinationals

- Partnerships and availability to sign confidentiality agreements
- Awareness of and compliance with good manufacturing practices and international production standards
- Research and Development with knowledge of materials, treatments and processes
- Ability to collaborate in developing product innovations
- Product and Quality Certifications
- Production planning and computer-based warehouse management
- Product consultancy
- Design and Development of new product lines on short term timelines

DENTAL IMPLANTS

Specialized in the design and realization of Certified Implant System  customized.

We use titanium bars (gr.5 ELI and gr.4 Cold Worked), exclusively of EU and US origin and in tolerance H6. This narrow dimensional rigor guarantees greater machining precision and compliance with nominal tolerances.

Follow-Up Non-Osteointegrations: under 3% compared to the average world value of 9/10 %

● **Over 80** Implant lines realized to date

● **Over 2.800.000** implants products to date

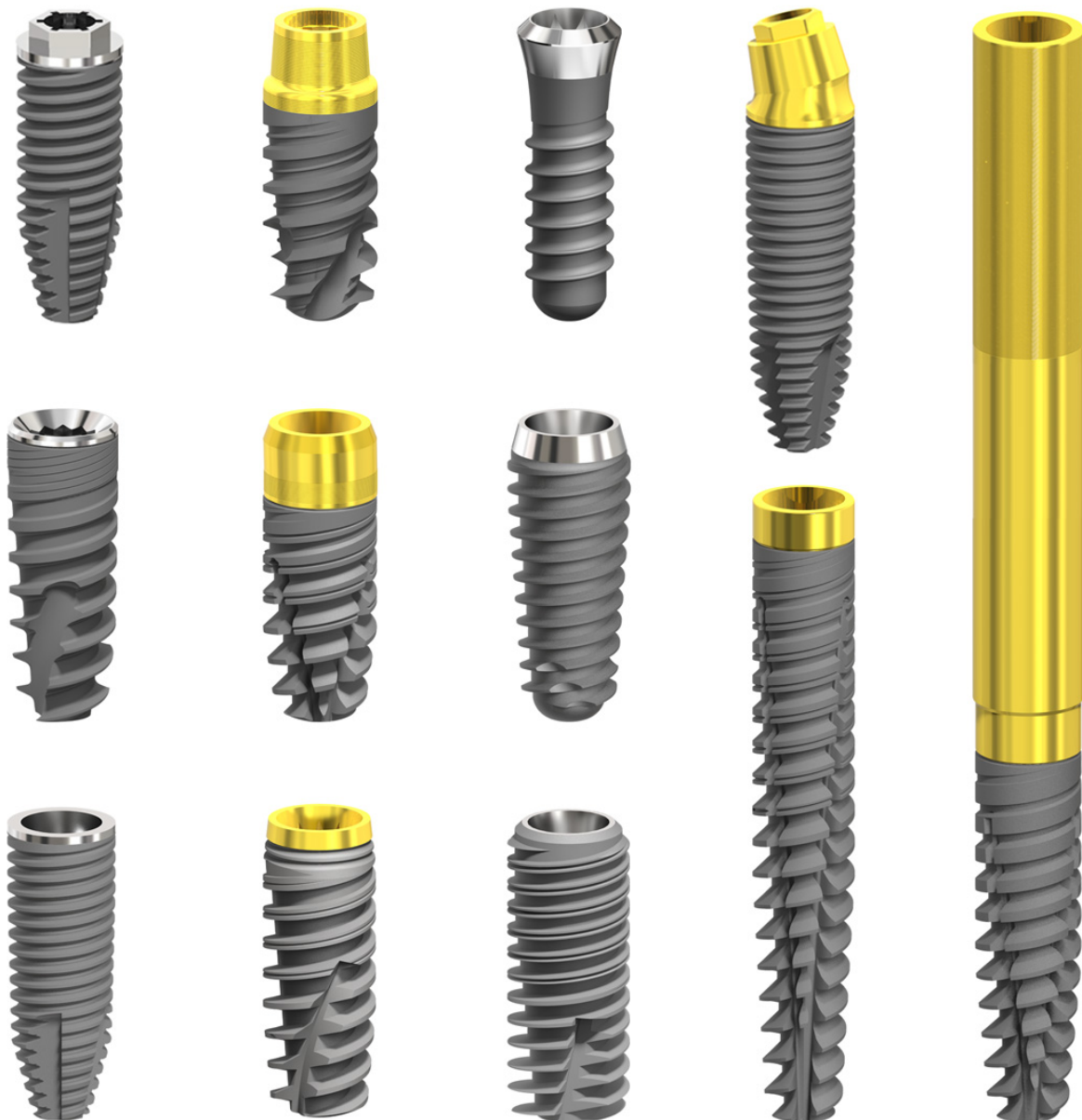

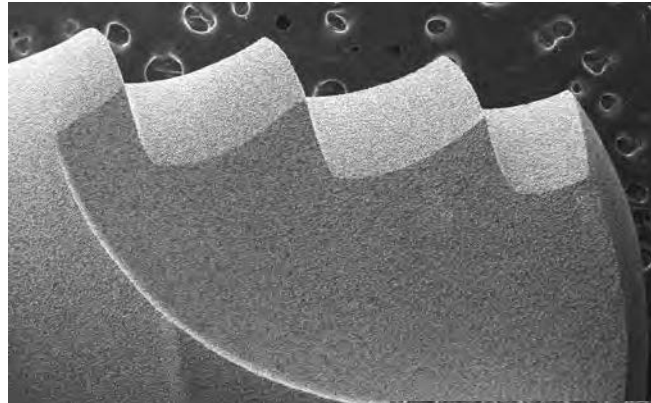

200 μm Mag = 75 X EHT = 15.00 kV
WD = 12.5 mm Signal A = SE1

RUGOSITY

Ra: $1.2 \div 2.0 \mu\text{m}$

Rt: $10.0 \div 20.0 \mu\text{m}$

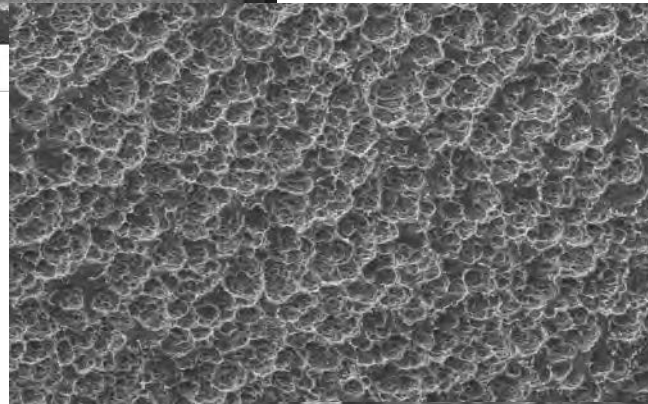

10 μm Mag = 1.00 K X
WD = 12.0 mm

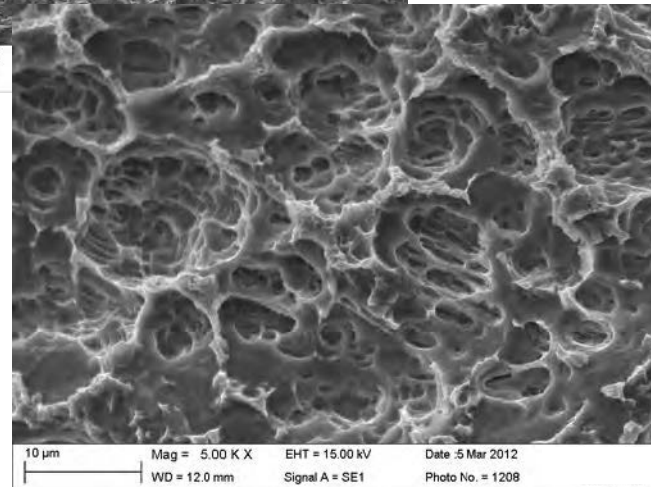

10 μm Mag = 5.00 K X EHT = 15.00 kV Date :5 Mar 2012
WD = 12.0 mm Signal A = SE1 Photo No. = 1208

RINEVA[®] SURFACE TREATMENT

Our exclusive RINEVA[®] Surface Treatment, obtained by sandblasting and double acidification, is very effective in platelet activation and coagulum retention in the implant site, withholding growth factors and ensuring a fast and favorable course of the bone healing process.

Study	Doctors	Year
Effects on the interfacial properties and cell adhesion of surface modification by the Peptic Hairy regions	Marco Morra, Clara Cassinelli, Giovanna Cascardo	2007
Titanium surfaces coated with collagen I: mesenchymal cell adhesion and in vivo evaluation in trabecular bone implants	Marco Morra, Clara Cassinelli, Giovanna Cascardo, L. Mazzucco, P. Borzini, Milena Fini, G. Giavaresi, Roberto Giardino	2007
Reduction of plaque accumulation on the hydrocarbon thin film deposited on the acrylic restoration polymers	M. Bellanda, Clara Cassinelli, Marco Morra	2008
Evaluation of the relationship between cost and quality of cleaning the surface of an implant system on the market	Marco Morra, Clara Cassinelli, Giovanna Cascardo, Daniele Bollati	2008
Cold plasma in the treatment of surfaces	Giovanna Cascardo, Clara Cassinelli	2012
Evaluation of the chemical composition of the surface, of the design, of the cytotoxicity and of the cell adhesion in dental implants	Marco Morra, Clara Cassinelli	2014

Study	Doctors	Year
Biological interactions on surface materials: understanding and control of proteins, cells and tissues	Marco Morra, Clara Cassinelli, Giovanna Cascardo, Daniele Bollati	2016
Titanium surfaces coated with collagen I for the bone implant	Marco Morra, Clara Cassinelli, Giovanna Cascardo, Daniele Bollati	2016
Effects of surface chemistry on the topographic modification of the surfaces of dental implants in titanium: in vitro experiments	Marco Morra, Clara Cassinelli, Giuseppe Bruzzone, Angelo Carpi, Giuseppe Di Santi, Roberto Giardino, Milena Fini	2016
Current and future perspectives of implant surfaces	Marco Morra, Clara Cassinelli, Giovanna Cascardo	2016
Comparative evaluation of cellular response to micro and nanotopographic patterns on implant surfaces	Marco Morra, Clara Cassinelli, Giovanna Cascardo, Daniele Bollati	2016
In vitro evaluation of the response of inflammatory cells to implant screws with different implant surfaces	Marco Morra, Clara Cassinelli, Fabio Colombelli, Daniele Bollati	2016

We have available an extensive documentation on tests and studies realized in collaboration with leading Universities and Institutes, such as in vitro studies, comparative tests, fatigue tests, SEM, XPS and EDX analyzes, X-RAY scans. The exclusive surface treatments are supported by a wide and authoritative bibliography.



PROSTHETICS COMPONENTS

Specialized in the design and construction of all the highly complex prosthetic components such as Multi-Unit Angled, Pre-Milled Blanks and Ti-Base.

● **Over 6.000.000** Components Products

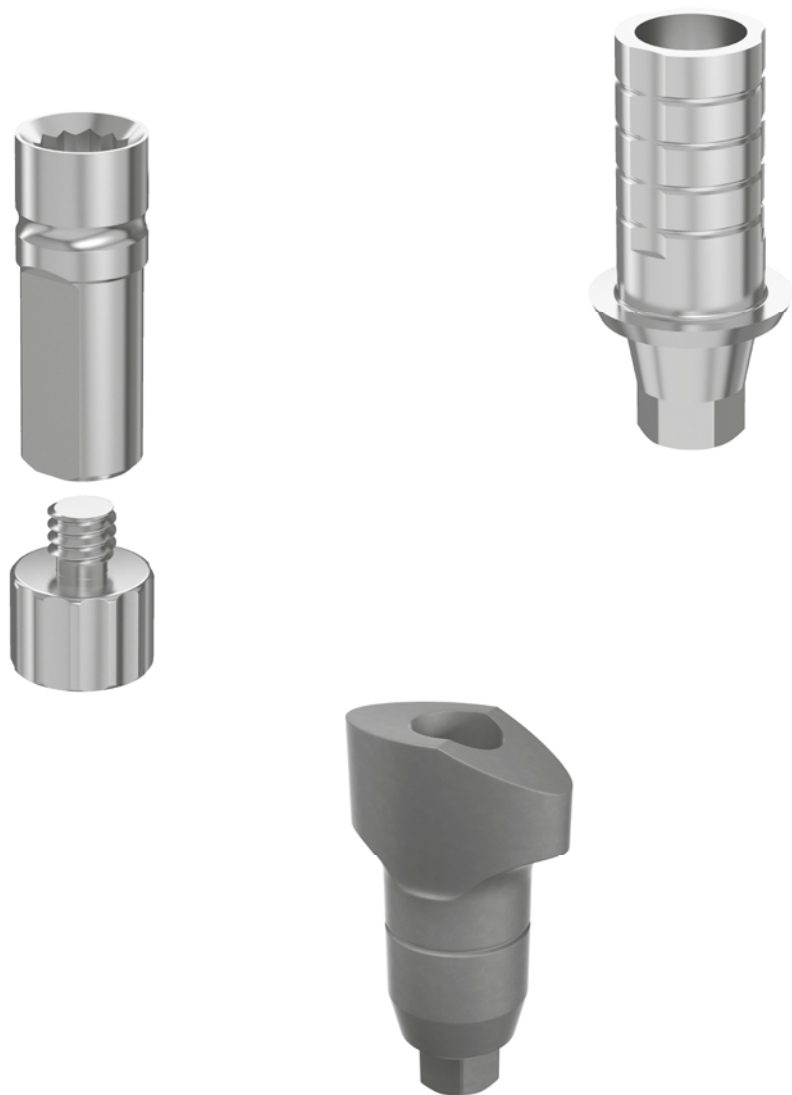

DIGITAL SOLUTIONS

- Production of components for digital technologies (Scan Body, 3D Analogs)
- Creation of customized implant libraries, inside in the main scanning and 3D modeling systems
dental wings **exocad** 3shape
- Qualified assistance in libraries management.



ACCESSORIES FOR IMPLANTOLOGY

- Surgical kits
- Surgical drills
- Accessories
- Kit for Guided Surgery
- Prosthetic Screw Removal Kit - SRS Dental
- Implant Removal Kit - SRI



ENDODONTIC POSTS IN GLASS AND CARBON FIBER

Specialized in the design and manufacture of Endodontic Posts in different types of Fibers, Certificates **CE-FDA** and customized. Available also Blistered and/or sterile.

Processing with the use of the best CNC technologies (Citizen), with lubrication in the absence of oils, to ensure maximum decontamination and greatly improve the adhesion of the post.

THE EVOLUTION THAT COMES FROM EXPERIENCE

Innovation, quality, high technology, scientific research and customized solutions. We offer different solutions in terms of line. This allows to have every specific post for every kind of canal anatomy and clinical case of reconstruction.

Pre-tensioned longitudinal fibers ensure a high aesthetic result, transmission of light inside the channel, also reducing the transmission of stress.

High mechanical properties, in addition to an excellent resistance to chewing loads, ensure its use in complex and extensive reconstructions.

The epoxy resin matrix has the characteristic of binding to the Bis Gma resin of all the main adhesion systems on the market, through the common free radicals.

The elastic modulus similar to that of dentin, reduces the transmission of stress on the walls, and prevents possible root fractures.

● **Over 30** Lines of pins produced to date

● **Over 20.000.000** Pins Products to date

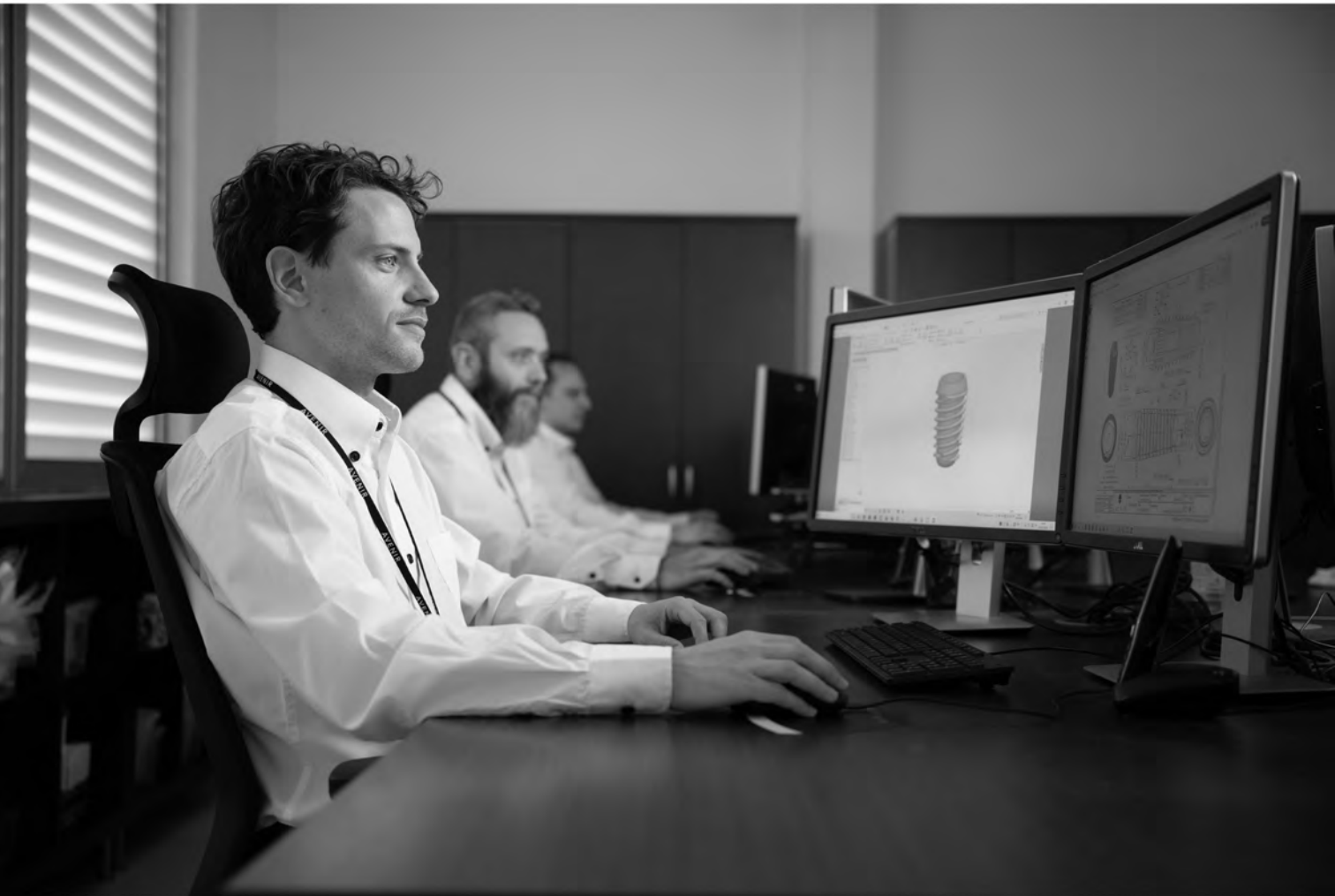

INTERNAL DESIGN

Thanks to a team of qualified engineers, using latest generation software such as SOLID WORKS, ESPRIT and SW Simulation Professional, we are able to offer different design solutions, both implementing and developing existing projects and “creating” products starting from customer concepts and specifications. All solutions are always made with “know how transfer” to the customer and supported by 3D virtual simulations (finite element method) to check innovations quickly and efficiently.



PRODUCTION

The best technology available on the market

stair **CITIZEN** **PRECISION TSUGAMI** **SCHNEEBERGER**

Our Production Machinery Park is composed by 24 units, 22 of which are CNC machines, with an expansion potential over 30 units.

Important Washing and Decontamination Equipments, Robotic Line for Titanium Anodic Coloration and Electropolishing/ Passivation of Steels, Laser Marking, Surface Treatment Laboratories, 2 Clean Room ISO8 with ISO5 hood processing, decontamination by Argon Plasma Reactor.



TITANIUM ANODIC COLORATION - STAINLESS STEEL ELECTROPOLISHING

- Advanced Electropolishing/passivation unit OF stainless steel, and Titanium Anodic Coloration of the latest generation.
- Computerized control of the proces
- Exclusive treatment methods



SHARPENING

New generation of 5-axis, robotic sharpening machine, allows to make milling cutters, ensuring perfect concentricity and maximum precision in the geometries and surface finish.



QUALITY CONTROL

- For each product a check list from 4 to 10 100% One by One checks
- Tolerance of 0.01 mm on the main dimensional dimensions to minimize micromovements, cause of possible unscrewings and loss of biological fitting.



CLEAN ROOM AND PACKAGING

- Packaging in ISO7 and ISO8 environment of all products, including non-sterile. Use of Blister e Tyvek products in ISO7 Clean Room.
- Assembling systems with No-Touch technology in ISO5 environment, to safeguard surface decontamination, realized with last passage in Argon plasma reactor



6 AUTOMATED WAREHOUSES

Computerized automation of product handling through the Modula Sintes1 system, with increased safety and optimized operating speed.



100% TRACEABILITY

Traceability system of each production phase through a barcode system, starting from the collection of the raw material, until the final release of the production batch, for which a sample of finished product and a piece of the bar is always filed. Labelling in controlled environment, realized with professional high-definition printers.

CERTIFICATIONS

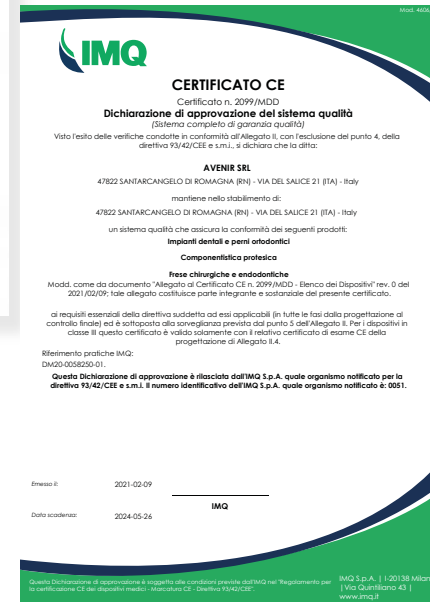

ISO 13485

The UNI CEI EN ISO 13485 rule specifically defines the requirements for a quality management system for manufacturers and distributors of medical devices. Compliance with the envisaged requirements is a guarantee that its products are designed, manufactured and marketed according to universally recognized and shared standards, always ensuring compliance with specific requirements and relevant laws.

ISO 9001

ISO 9001 is a regulation that proposes a Management System able to ensure products and/or services that meet the requirements specified by the Customer or the applicable binding requirements. Its application requires the company to search for efficiency and optimize its organizational structure in pursuit of continuous improvement.

CERTIFICATION CE

The marking **CE** ensures compliance with the essential requirements of the EU Regulation MDR 2017/745. This Regulation, specific for medical devices, ensures compliance of the products with essential safety and quality requirements, to ensure that the Manufacturer must guarantee the governance of all the processes, from the control on the materials to the control of the different phases of the production process, until at the final test and product release. Guaranteeing the traceability of materials, production records up to delivery to the customer/end user. Update **EXTENSION CE MARKING** Regulation MDR 2017/745 classification of abutments and prosthetic screws from Class IIa to Class IIb.

ISO 45001

Certification based on occupational health and safety management, it requires organizations to continuously improve, guarantee of compliance with the specified safety policies.

ISO 14001

Based on the "Plan-Do-Check-Act" methodology, it provides a systematic framework for integrating environmental protection practices, preventing pollution, reducing the amount of waste, energy and material consumption.



Discovering our world,
through Experience,
Innovation and Technology.